



Wind Load Report

1. Site & Building Data

Roof Type: Gable
 Wind Speed (ult): 118 mph
 Exposure Category: C
 Enclosure Class: Enclosed
 Building Width (W): 34 ft.
 Building Length (L): 34 ft.
 Eave Height (h_e): 24 ft.
 Foundation Height (h_f): 0 ft.
 Roof Pitch: 12 /12
 Eave Overhang (OH_e): 0 ft.
 Gable Overhang (OH_g): 0 ft.

2. Parameters & Coefficients

Topographic Factor (K_{zt}): 1.0
 Directionality Factor (K_d): .85
 Roof Angle (θ): 45.00 deg.
 Mean Roof Height (h): 32.50 ft.
 Ridge Height (h_r): 41.00 ft.
 Pos. Internal Pressure (+GC_{pi}): +0.18
 Neg. Internal Pressure (-GC_{pi}): -0.18
 Velocity Pressure Exp. Coeff. (K_h): 1.00 @ z=h
 Velocity Pressure (q_h): 30.27 psf
 End Zone Width (a): 3.00 ft.
 Zone 2/2E Dist.: 17.00 ft.

3. Design Assumptions and Notes

Code Standard: ASCE 7-10
 Geometry: Regular-Shaped Bldg.
 Height Class: Low-Rise Building
 Notes:

4. Design Loads

Top Chord Dead Load: 7 psf
 Bottom Chord Dead Load: 10 psf
 Truss/Rafter Spacing: 24 in. o/c

4. Design Wind Pressures: MWFRS Envelope Procedure

Load Case A: Transverse Direction			
Surface	GC _{pf}	Design Pressure (psf)	
		(w/ +GC _{pi})	(w/ -GC _{pi})
1	0.56	11.50	22.40
2	0.21	0.91	11.80
3	-0.43	-18.46	-7.57
4	-0.37	-16.65	-5.75
1E	0.69	15.44	26.33
2E	0.27	2.72	13.62
3E	-0.53	-21.49	-10.59
4E	-0.48	-19.98	-9.08

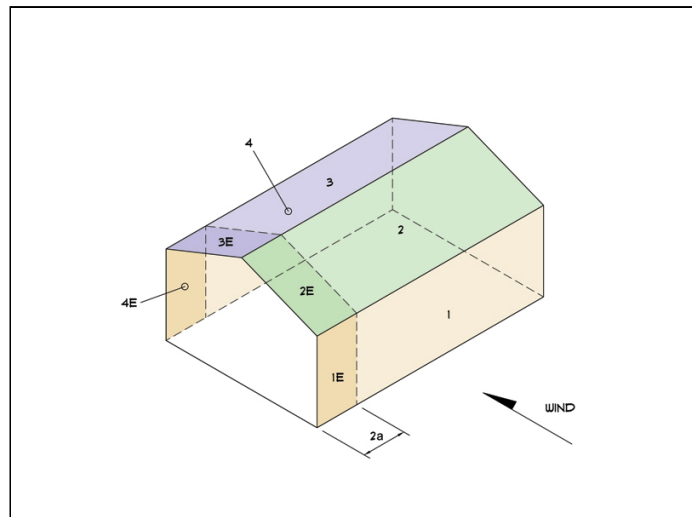

- a) (+) and (-) signs signify wind pressures acting toward & away from surfaces.
- b) External Pressure Coefficients linearly interpolated from Fig. 28.4-1 ASCE 7-10.
- c) Design building for all wind directions, 4 load patterns per load case.
- d) Total horizontal shear shall not be less than that by neglecting roof wind forces.
- e) Min. wind load for enclosed or partially enclosed bldg.: 16 psf wall, 8 psf roof.
- f) Design pressures are for strength design, multiply by 0.6 for ASD.

Subject Wind Loads	Customer	Location	Job No. 2026D47
Engr. Engineer Name	ENGINEERING COMPANY INC.		Rev. -
Date 3/25/2026	Street Address City, CA 99999 ph. (800) 000-0000 www.website.com		Page 1



This report may not be copied, reproduced or distributed without the written consent of Engineering Company Inc.

Load Case B: Longitudinal Direction

Surface	GCpf	Design Pressure (psf)	
		(w/ +GCpi)	(w/ -GCpi)
1	-0.45	-19.07	-8.17
2	-0.69	-26.33	-15.44
3	-0.37	-16.65	-5.75
4	-0.45	-19.07	-8.17
5	0.40	6.66	17.55
6	-0.29	-14.23	-3.33
1E	-0.48	-19.98	-9.08
2E	-1.07	-37.83	-26.94
3E	-0.53	-21.49	-10.59
4E	-0.48	-19.98	-9.08
5E	0.61	13.01	23.91
6E	-0.43	-18.46	-7.57

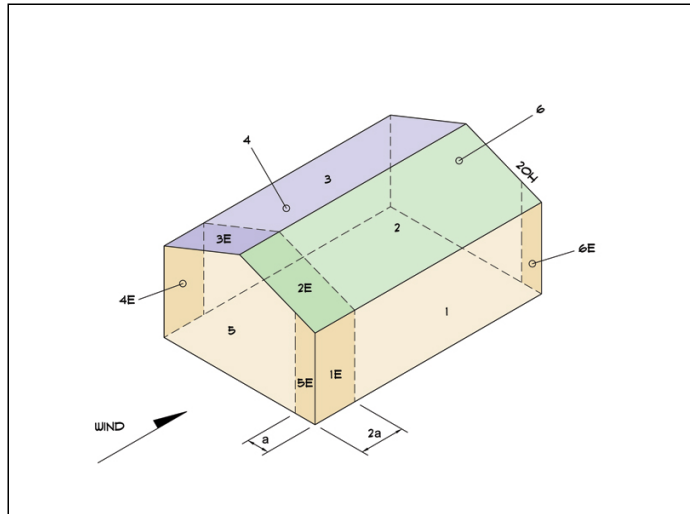

- a) (+) and (-) signs signify wind pressures acting toward & away from surfaces.
- b) External Pressure Coefficients linearly interpolated from Fig. 28.4-1 ASCE 7-10.
- c) Design building for all wind directions, 4 load patterns per load case.
- d) Total horizontal shear shall not be less than that by neglecting roof wind forces.
- e) Min. wind load for enclosed or partially enclosed bldg.: 16 psf wall, 8 psf roof.
- f) Design pressures are for strength design, multiply by 0.6 for ASD.

Torsional Load Cases

Surface	Load Case	GCpf	Design Pressure (psf)	
			(w/ +GCpi)	(w/ -GCpi)
1T	A	-	2.88	5.60
2T	A	-	0.23	2.95
3T	A	-	-4.62	-1.89
4T	A	-	-4.16	-1.44
5T	B	-	1.66	4.39
6T	B	-	-3.56	-0.83

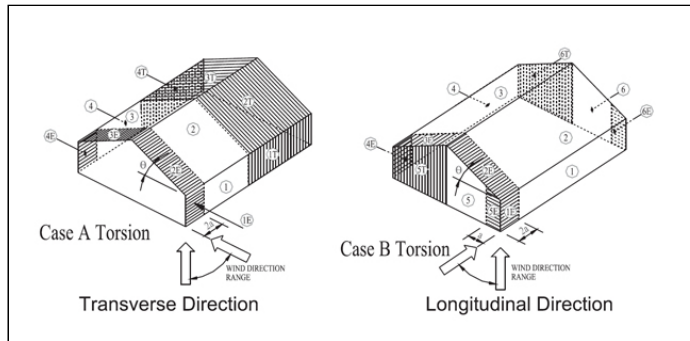

- a) (+) and (-) signs signify wind pressures acting toward & away from surfaces.
- b) Pressures designated with a "T" are 25% of full design wind pressures.
- c) Torsional loading shall apply to all 8 load patterns using the figures shown.
- d) Design pressures are for strength design, multiply by 0.6 for ASD.
- e) Torsional Design Exceptions: One story bldg. with $h \leq 30$ ft,
Two stories or less framed with light frame construction,
Two stories or less with flexible diaphragms.

Subject Wind Loads	Customer	Location	Job No. 2026D47
Engr. Engineer Name	ENGINEERING COMPANY INC. Street Address City, CA 99999 ph. (800) 000-0000 www.website.com		Rev. -
Date 3/25/2026			Page 2



This report may not be copied, reproduced or distributed without the written consent of Engineering Company Inc.

5. Wind Load Calculations

1.) Lateral Loads - Transverse Direction:

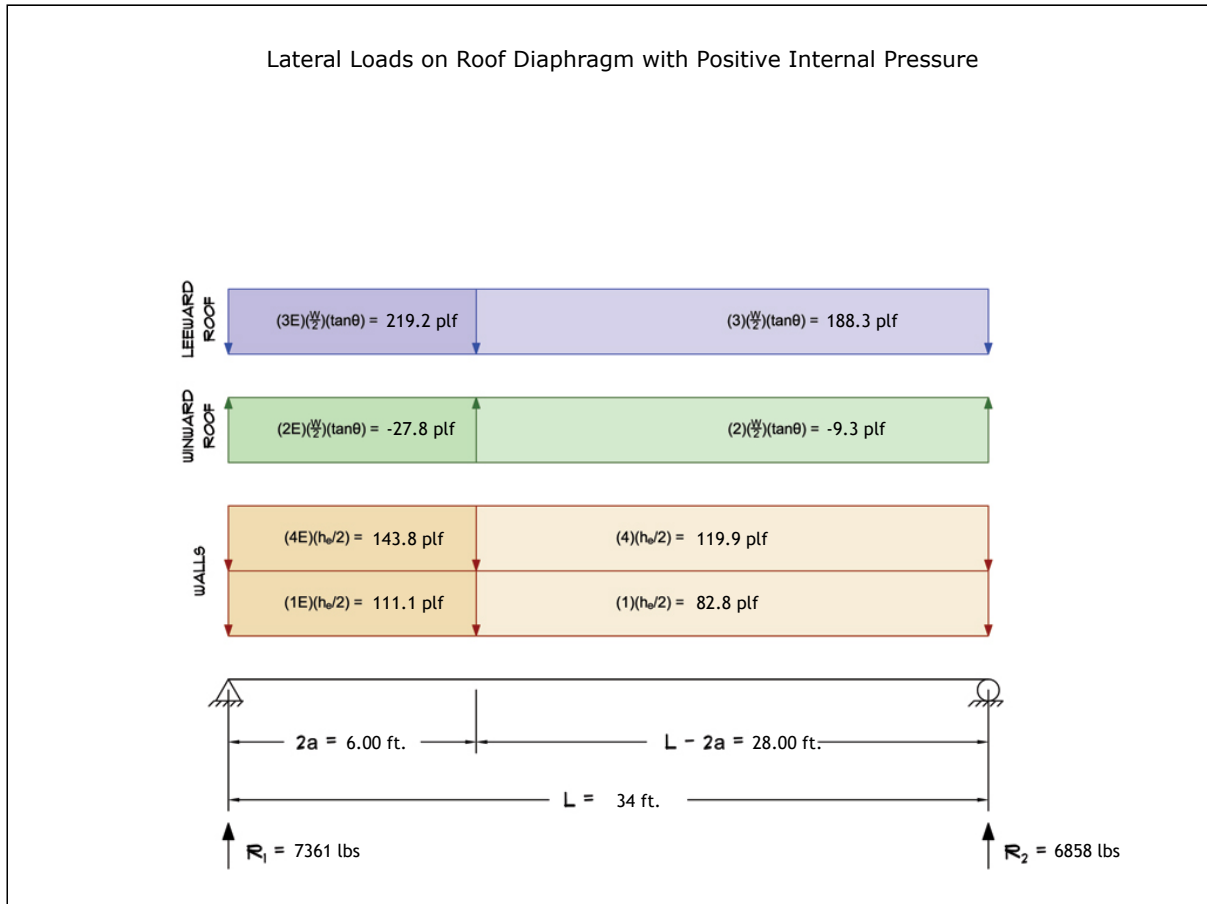

- a) (-) signs signify wind lateral forces acting opposite to the direction of the arrows shown.
b) Strength design values multiplied by 0.6 to obtain ASD values.

Wind Base Shear (ASD)						
Load Case A: Transverse Direction						
Load Case	Walls (lbs)	Roof (lbs)	Roof Overhangs (lbs)	Total Lateral Load (lbs)	R ₁ (lbs)	R ₂ (lbs)
Positive Internal Pressure	7204	7014	0	14219	7361	6858
Negative Internal Pressure	7204	7014	0	14219	7361	6858
Roof Pressure = 0	7204	0	0	7204	3731	3473
Min. Pressures (8 psf, 16 psf)	3917	2774	0	6691	3346	3346

- a) Bottom half of wall neglected in tributary area calculations.
b) Strength design values multiplied by 0.6 to obtain ASD values.

Subject Wind Loads	Customer	Location	Job No. 2026D47
Engr. Engineer Name	ENGINEERING COMPANY INC.		Rev. -
Date 3/25/2026	Street Address City, CA 99999 ph. (800) 000-0000 www.website.com		Page 3



This report may not be copied, reproduced or distributed without the written consent of Engineering Company Inc.

2.) Lateral Loads - Longitudinal Direction:

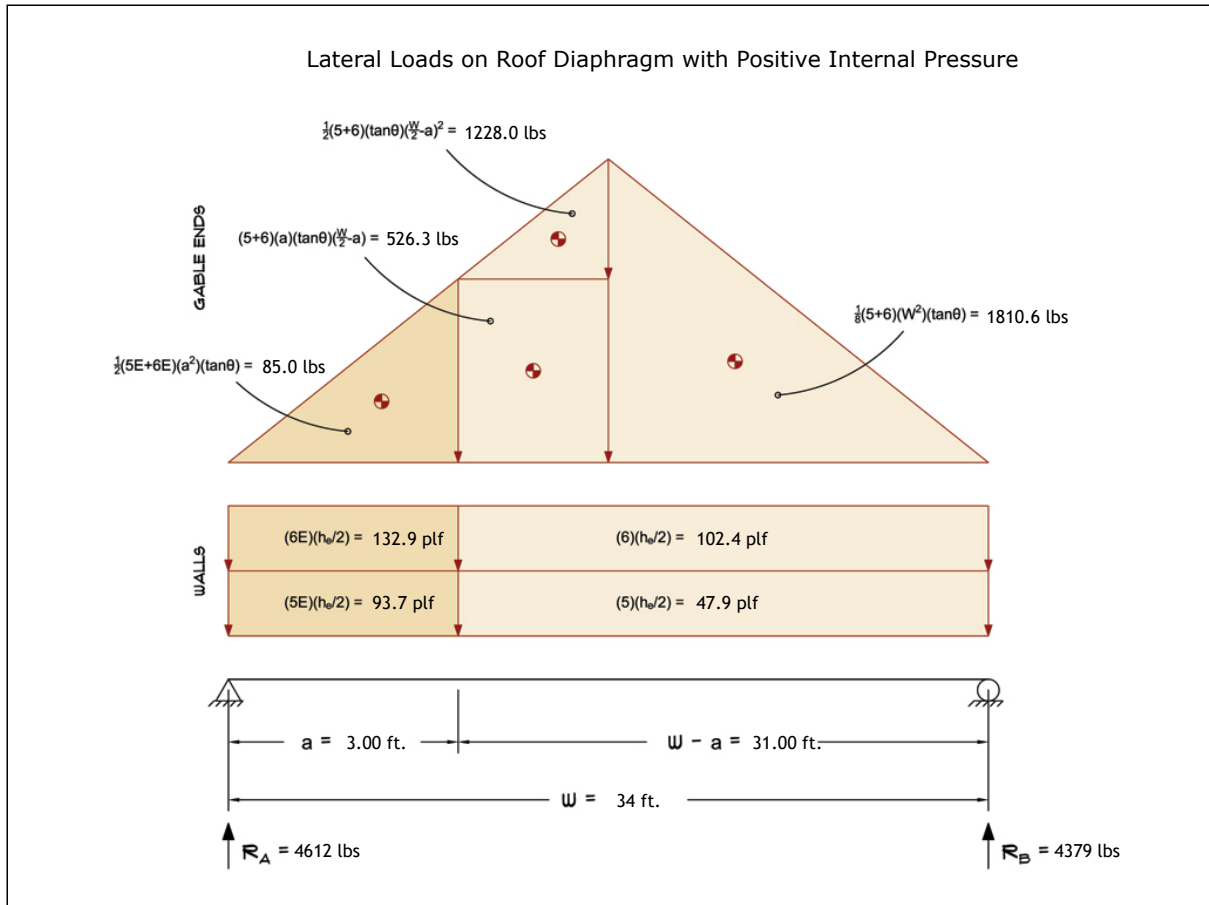

- a) (-) signs signify wind lateral forces acting opposite to the direction of the arrows shown.
- b) Strength design values multiplied by 0.6 to obtain ASD values.
- c) Where the length of building (L) exceeds 4X the mean roof height (h), wind drag forces should additionally be considered.

Wind Base Shear (ASD)						
Load Case B: Longitudinal Direction						
Load Case	Walls (lbs)	Gable Ends (lbs)	Roof (lbs)	Total Lateral Load (lbs)	R _A (lbs)	R _B (lbs)
Positive Internal Pressure	5341	3650	0	8991	4612	4379
Negative Internal Pressure	5341	3650	0	8991	4612	4379
Roof Pressure = 0	5341	3650	0	8991	4612	4379
Min. Pressures (8 psf, 16 psf)	3917	2774	0	6691	3346	3346

- a) Bottom half of wall neglected in tributary area calculations.
- b) Strength design values multiplied by 0.6 to obtain ASD values.

Subject Wind Loads	Customer	Location	Job No. 2026D47
Engr. Engineer Name	ENGINEERING COMPANY INC. Street Address City, CA 99999 ph. (800) 000-0000 www.website.com		Rev. -
Date 3/25/2026			
			This report may not be copied, reproduced or distributed without the written consent of Engineering Company Inc. Copyright © 2026

3.) Roof Truss Reactions:

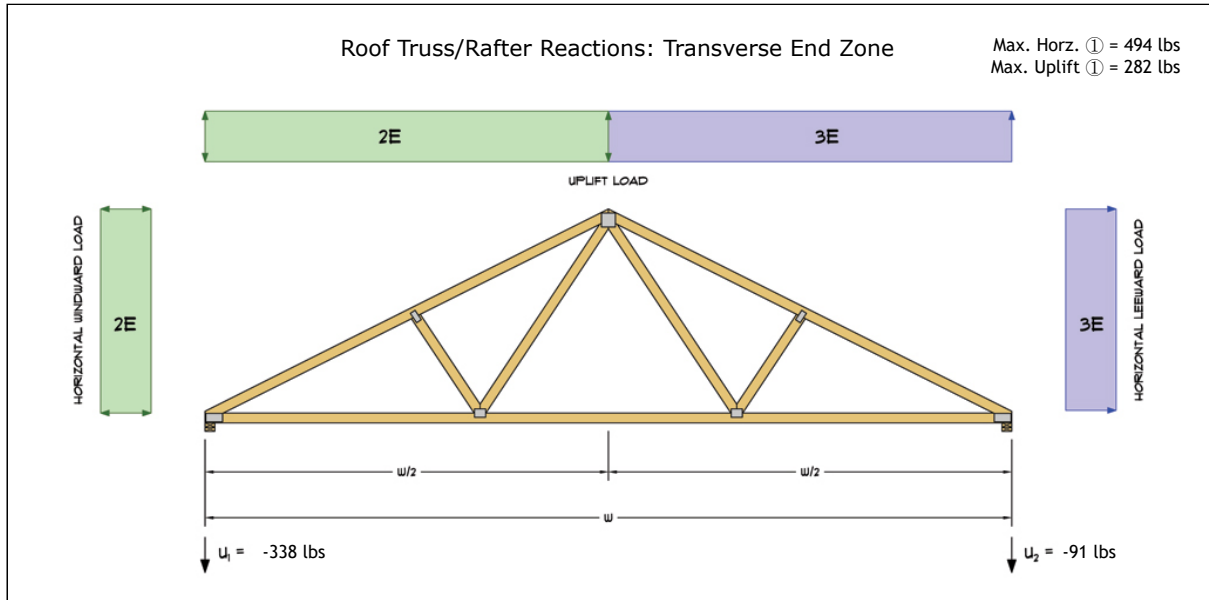

- a) Strength design values multiplied by 0.6 to obtain ASD values.
- b) Windward loads may be positive or negative depending on pitch of roof.

Roof Truss/Rafter Reactions (ASD)					
w/ Positive Internal Pressure					
Load Case	Horizontal Load (lbs)	Gross Uplift (lbs)	Net Uplift (lbs)	U ₁ (lbs)	U ₂ (lbs)
Transverse Int. Zone	-395	358	-454	-326	-128
Transverse End Zone	-494	383	-429	-338	-91
Longitudinal Int. Zone	198	877	65	82	-17
Longitudinal End Zone	333	1210	398	282	116

- a) Gross Uplift calculations do not include any counteracting roof dead loads.
- b) Net Uplift calculations include counteracting roof dead loads multiplied by 0.6 per load case (7) ASCE 7-10.
- c) Strength design values multiplied by 0.6 to obtain ASD values for wind loads.
- d) Loads based on truss spacing calculated at 24" o/c.
- e) Negative values for horizontal load indicate load acting in windward direction (transverse load cases).
- f) Negative values for uplift indicate net downward force (zero uplift).

*Disclaimer: The calculations produced herein are for initial design and estimating purposes only. The calculations and drawings presented do not constitute a fully engineered design. All of the potential load cases required to fully design an actual structure may not be provided by this calculator. For the design of an actual structure, a registered and licensed professional should be consulted as per IRC 2012 Sec. R802.10.2 and designed according to the minimum requirements of ASCE 7-10. The wind load calculations provided by this online tool are for educational and illustrative purposes only. Medeek Design assumes no liability or loss for any designs presented and does not guarantee fitness for use.

Subject Wind Loads	Customer	Location	Job No. 2026D47
Engr. Engineer Name	ENGINEERING COMPANY INC. Street Address City, CA 99999 ph. (800) 000-0000 www.website.com		Rev. -
Date 3/25/2026			
This report may not be copied, reproduced or distributed without the written consent of Engineering Company Inc. Copyright © 2026			