

Principles of Mechanics Model for Wood Structural Panel Portal Frames

Authors:

Zeno Martin, APA-The Engineered Wood Association, Tacoma, WA, zeno.martin@apawood.org

Thomas D. Skaggs, APA-The Engineered Wood Association, Tacoma, WA,
tom.skaggs@apawood.org

Edward L. Keith, APA-The Engineered Wood Association, Tacoma, WA, ed.keith@apawood.org

Borjen Yeh, APA-The Engineered Wood Association, Tacoma, WA, borjen.yeh@apawood.org

ABSTRACT

A principles of mechanics model to predict the strength of wood structural panel portal frames has been developed. The wood structural panel portal frame consists of a wood structural panel overlapping a header to form a moment resisting connection to resist in-plane lateral loads. The advantage of portal frames is that they can resist relatively high lateral loads for a small wall width. The model is based on moment couples and shear strength of the components. Model predictions are compared to test results for a variety of portal frame constructions that have been tested. All portal frame walls were tested with the SEAOSC [1996] SPD cyclic load protocol for in-plane shear resistance.

Portal frame constructions investigated in this study range from 16 to 24-inch wide, 8 to 10-ft tall, sheathed with OSB or plywood, and with and without hold down devices at the base of the wall segment. Also investigated are portal frames built on raised wood floor assemblies with variable base of wall restraint configurations which are modeled with moment couples.

The model is compared to ten unique portal frame constructions that were tested. Comparing the model to the test results shows that the model accurately predicts the strength to within about 5% on average.

OVERVIEW

This report presents a principles of mechanics model to predict the in-plane lateral racking strength, V , of a wood structural panel portal frame design. The general theory is as follows by Equations 1-3 and Figure 1:

$$V = \text{Minimum of: } V_{\text{moment couples}}, V_{\text{shear strength}} \quad (1)$$

$$V_{\text{moment couples}} = (M_{\text{top}} + M_{\text{bottom}}) / H \quad (2)$$

$$V_{\text{shear strength}} = \text{Minimum of: } v_{\text{panel}}, v_{\text{nails}}, v_{\text{base connection}} \quad (3)$$

Where:

M_{top} = Minimum of: sheathing to header fastener moment capacity plus moment capacity due to header strap, or sheathing bending strength plus the moment capacity due to header strap

M_{bottom} = Tie down strap capacity times wall width plus sheathing to sill plate nailing moment capacity

H = Wall height

v_{panel} = Wood structural panel shear-through-thickness strength

v_{nails} = Wood structural panel-to-framing shear capacity

$v_{base\ connection}$ = Shear capacity due to base of wall connections to supporting structure

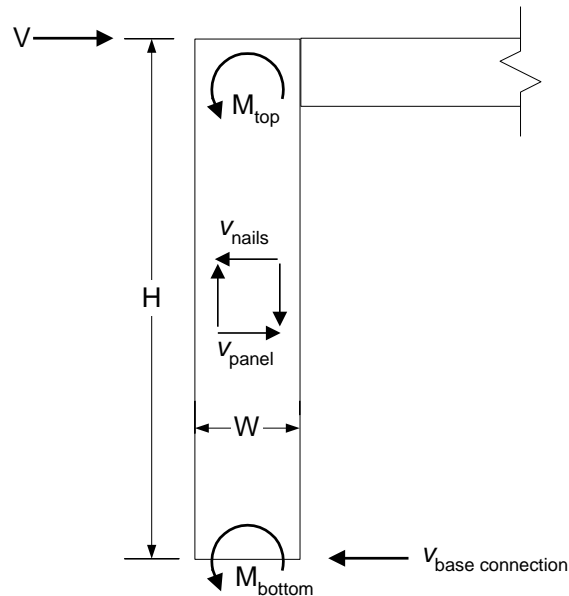

FIGURE 1. PRINCIPLES OF MECHANICS MODEL TO PREDICT THE STRENGTH OF THE WOOD STRUCTURAL PANEL PORTAL FRAME

In this paper, 10 different portal frame designs are modeled, corresponding to 10 matched portal frame tests. The exact details of the general method will be shown by example.

SHEATHING FASTENER MOMENT CAPACITIES

The fastener group moment capacities are calculated by first computing the polar moment of inertia of the fastener group. The single fastener allowable lateral load capacity is determined in accordance with the NDS [2005]. Given the polar moment of inertia for the fastener group and the allowable single fastener lateral load capacity, the following formula is used to compute the allowable moment capacity of the connection:

$$M = Z'(J) / r \quad (4)$$

Where:

Z' = single fastener allowable lateral load capacity per the NDS.

J = polar moment of inertia.

r = distance to critical or average fastener.

The fastener group moment capacity can be computed using the average fastener or the critical fastener (that fastener located the furthest from the centroid of the fastener group). When using the distance to the critical fastener, the maximum moment is computed based on the assumption that the critical fastener will not exceed its allowable lateral load, and all other fasteners will be loaded to less than their allowable load.

When using the distance to the average fastener, the maximum moment is based upon a theoretical average fastener. The maximum moment of the fastener group is based on this fastener being stressed to its maximum allowable lateral load value. As a result of using the average fastener method, the moment capacity is increased at the expense of overstressing those fasteners that are further from the centroid of the fastener group than the theoretical average fastener. Because of this, it is necessary to check the load on the critical fastener to see if the computed overload can be tolerated.

In this report, there are 5 different fastener moment capacity cases calculated, as shown in Figure 2. A calculation example for the “(1) Header Fastener Moment” for both critical and average distances is provided in Appendix A.

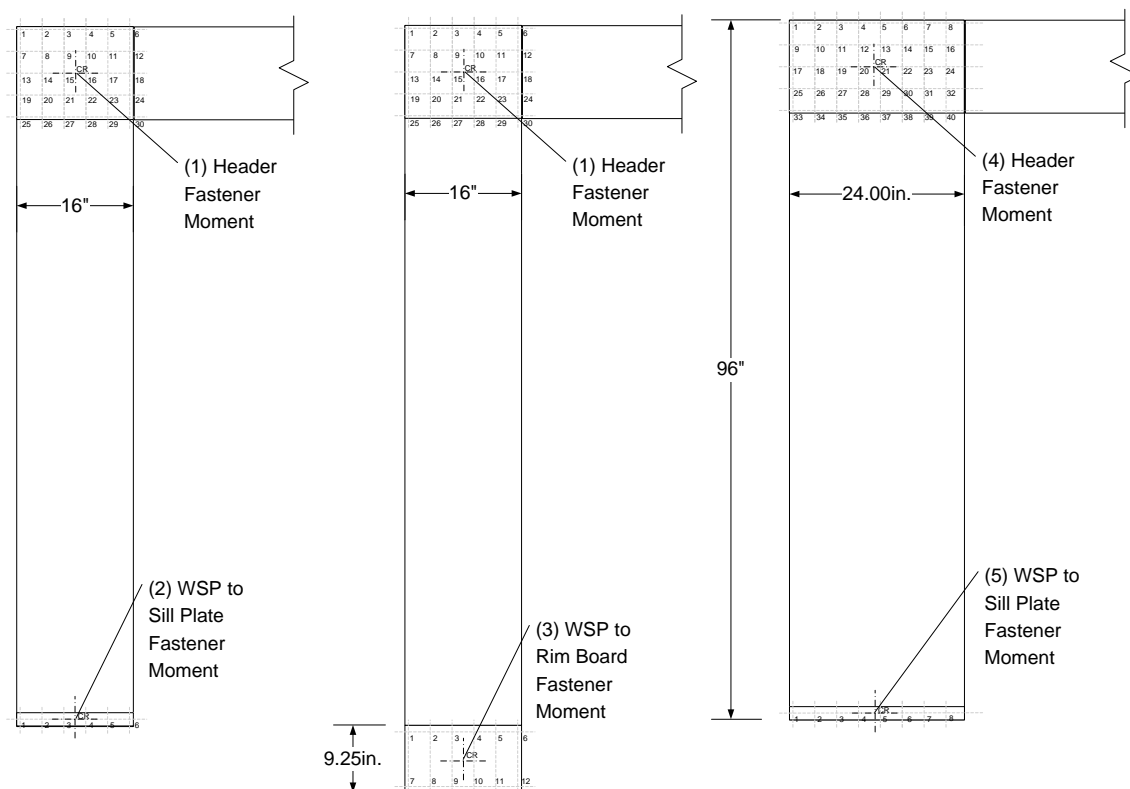

FIGURE 2. THE FIVE DIFFERENT FASTENER MOMENT CAPACITY CASES

CALCULATION PROCEDURE

The calculation procedure simply follows Equations 1-4. A complete example calculation for Wall #1 is provided in Appendix B. Material properties for the wood structural panels (plywood

and OSB) are taken from the Panel Design Specification (PDS) [APA, 2007], and APA Performance-Rated Rimboard [APA, 2004].

CALCULATION RESULTS

The calculated results are completed for ten different walls that have been tested at APA, as summarized in Table 1 [APA, 2002; 2003a; 2003b; 2004; 2006]. Following the calculation procedures previously described, Tables 2 and 3 provide a summary of the calculated values compared to the ultimate strength values divided by 3. In this report, the 3 is used as the safety factor, or margin, between ultimate strength and “allowable” design value. Safety factors near 3 have historically been used with wood shear wall assemblies, and the value of 2.8 is currently used in the product standard PS-2 [2004] for wood structural panel (WSP) shear walls. All sheathing thicknesses were 3/8” except Wall #7 used 7/16”, as shown in Table 2. Note that for Wall #10, the sheathing was 3/8” plywood which has an effective thickness of 0.155” per the PDS.

Wall #	Description	APA Test Report Reference
1	16" x 120" Portal frame with hold down	T2003-11: Tests 1 and 2
2	16" x 96" Portal frame with hold down	T2002-46: Test 3
3	16" x 96" Portal frame with hold down	T2002-46: Test 9
4	24" x 120" Portal frame with hold down	T2003-11: Tests 3 and 4
5	24" x 96" Portal frame with hold down	T2002-46: Test 5
6	24" x 96" Portal frame with hold down	T2002-46: Test 10
7	16" x 96" Portal frame without hold down	T2006-29: Test 9
8	16" x 96" Portal frame on a raised floor with LTP4 hold down	T2004-38: Test 8
9	16" x 96" Portal frame on a raised floor with 9.25" WSP overlap on rim board	T2004-38: Test 10
10	16" x 96" Plywood Portal frame without hold down	T2006-29: Test 6

TABLE 1. SUMMARY OF WALLS ANALYZED AND APA TEST REPORT REFERENCED

DISCUSSION OF RESULTS

As shown in Tables 2 and 3 the calculated results are very close to the tested results divided by 3 for a variety of tested boundary conditions. The critical fastener method slightly, (3%), under-predicts on average, while the average fastener method slightly, (4%), over-predicts on average.

LIMITATIONS

The model presented is confirmed to be generally accurate for strength design; however it doesn't include racking deflection. At present, racking deflection information can be obtained from the empirical data available or a deflection model could be developed. However such a model is rather complex.

The combined effects of vertical and lateral loads have not been investigated. However, it is theorized that the minimum required header stiffness “worst case” (a double 2x12 with clear span of 18 ft) provides sufficient rigidity under allowable vertical loads that it doesn't impart

#	Width (in.)	Height (in.)	Step 1. V based on moment couples											Step 2. V based on shear strength							Step 3.	Tested Lateral Capacity / 3	Compare to Tested ^(d)		
			M _{bottom}			M _{top}								V _{moment couples}	V _{panel}			V _{nails}		V _{base}				V _{shear}	V ^(c)
			Tie down strap	WSP to Sill	M _{bottom}	Header Fastener	Sheathing M			Header Strap		Fvtv	V		Z	Nail studs									
							M	type	Fb	t	M					M ^(b)	M _{top}	#nail	V						
(lb)	M ^(a) (lb-in.)	M	(lb-in.)	M	type	Fb	t	M	(lb)	M ^(b) (lb-in.)	M _{top} (lb-in.)	(lb)	(lb/in.)	(lb)	(lb)	s/ft	(lb)	(lb)	(lb)	(lb)					
1	16	120	4200	54600	2386	56986	15701	OSB	600	0.375	15360	1000	14500	29860	724	155	3968	71.0	10	1515	1920	1515	724	725	0%
2	16	96	4200	54600	2386	56986	15701	OSB	600	0.375	15360	1000	14500	29860	905	155	3968	71.0	10	1515	1920	1515	905	886	2%
3	16	96	4200	54600	2386	56986	15701	OSB	600	0.375	15360	2400	15360	30720	914	155	3968	71.0	10	1515	1920	1515	914	947	-3%
4	24	120	4200	88200	4090	92290	24517	OSB	600	0.375	34560	1000	22500	47017	1161	155	5952	71.0	10	2272	1920	1920	1161	1209	-4%
5	24	96	4200	88200	4090	92290	24517	OSB	600	0.375	34560	1000	22500	47017	1451	155	5952	71.0	10	2272	1920	1920	1451	1671	-13%
6	24	96	4200	88200	4090	92290	24517	OSB	600	0.375	34560	2400	34560	59077	1577	155	5952	71.0	10	2272	1920	1920	1577	1476	7%
7	16	96	0	0	2453	2453	16143	OSB	600	0.438	17920	1000	14500	30643	345	155	3968	73.0	10	1557	2080	1557	345	380	-9%
8	16	96	670	8710	0	8710	15701	OSB	600	0.375	15360	1000	14500	29860	402	155	3968	71.0	10	1515	1906	1515	402	377	7%
9	16	96	0	0	6664	6664	15701	OSB	600	0.375	15360	1000	14500	29860	380	155	3968	71.0	10	1515	1929	1515	380	382	0%
10	16	96	0	0	2117	2117	13932	PLY	1238	0.155	26189	1000	14500	28432	318	53	1357	63.0	10	1344	2080	1344	318	371	-14%

average = -3%

- (a). Hold down M = strap capacity times width - 3"
- (b). Header strap moment capacity = strap capacity times width - 1.5", but shall not exceed sheathing moment capacity
- (c). V = minimum of V based on moment couples and V based on shear strength
- (d). Comparison is: (V/Tested)-1 x 100%

TABLE 2. SUMMARY OF THE CALCULATED VALUE AND THE TESTED VALUES FOR THE CRITICAL FASTENER METHOD.

#	Width (in.)	Height (in.)	Step 1. V based on moment couples											Step 2. V based on shear strength							Step 3.	Tested Lateral Capacity / 3	Compare to Tested ^(d)		
			M _{bottom}			M _{top}								V _{moment couples}	V _{panel}			V _{nails}		V _{base}				V _{shear}	V ^(c)
			Tie down strap	WSP to Sill	M _{bottom}	Header Fastener	Sheathing M			Header Strap		Fvtv	V		Z	Nail studs									
							M	type	Fb	t	M					M ^(b)	M _{top}	#nail	V						
(lb)	M ^(a) (lb-in.)	M	(lb-in.)	M	type	Fb	t	M	(lb)	M ^(b) (lb-in.)	M _{top} (lb-in.)	(lb)	(lb/in.)	(lb)	(lb)	s/ft	(lb)	(lb)	(lb)	(lb)					
1	16	120	4200	54600	3976	58576	24126	OSB	600	0.375	15360	1000	14500	29860	737	155	3968	71.0	10	1515	1920	1515	737	725	2%
2	16	96	4200	54600	3976	58576	24126	OSB	600	0.375	15360	1000	14500	29860	921	155	3968	71.0	10	1515	1920	1515	921	886	4%
3	16	96	4200	54600	3976	58576	24126	OSB	600	0.375	15360	2400	15360	30720	930	155	3968	71.0	10	1515	1920	1515	930	947	-2%
4	24	120	4200	88200	7157	95357	39458	OSB	600	0.375	34560	1000	22500	57060	1270	155	5952	71.0	10	2272	1920	1920	1270	1209	5%
5	24	96	4200	88200	7157	95357	39458	OSB	600	0.375	34560	1000	22500	57060	1588	155	5952	71.0	10	2272	1920	1920	1588	1671	-5%
6	24	96	4200	88200	7157	95357	35498	OSB	600	0.375	34560	2400	34560	69120	1713	155	5952	71.0	10	2272	1920	1920	1713	1476	16%
7	16	96	0	0	4088	4088	24806	OSB	600	0.438	17920	1000	14500	32420	380	155	3968	73.0	10	1557	2080	1557	380	380	0%
8	16	96	670	8710	0	8710	24806	OSB	600	0.375	15360	1000	14500	29860	402	155	3968	71.0	10	1515	1906	1515	402	377	7%
9	16	96	0	0	9105	9105	24126	OSB	600	0.375	15360	1000	14500	29860	406	155	3968	71.0	10	1515	1929	1515	406	382	6%
10	16	96	0	0	3528	3528	21408	PLY	1238	0.155	26189	1000	14500	35908	411	53	1357	63.0	10	1344	2080	1344	411	371	11%

average = 4%

- (a). Hold down M = strap capacity times width - 3"
- (b). Header strap moment capacity = strap capacity times width - 1.5", but shall not exceed sheathing moment capacity
- (c). V = minimum of V based on moment couples and V based on shear strength
- (d). Comparison is: (V/Tested)-1 x 100%

TABLE 3. SUMMARY OF THE CALCULATED VALUE AND THE TESTED VALUES FOR THE AVERAGE FASTENER METHOD.

Downloaded from ascelibrary.org by Nathaniel Wilkerson on 11/11/14. Copyright ASCE. For personal use only; all rights reserved.

significant moment into the wall segment. On the other hand, the larger deformations associated with design lateral loads do impart moment (header fastener moment in Tables 2 and 3) into the header. Similar treatment of combined lateral and vertical loads can be seen in design information for prefabricated wood portal frame segments from Simpson Strong Tie [2007] and i-Level [2006].

SUMMARY AND CONCLUSIONS

A principles of mechanics model is presented to determine the strength of wood structural panel portal frames. Details of the calculations, including complete sample calculations are provided. The analytical model compares very well, within 5% on average, to the test results for a range of portal frame constructions.

REFERENCES

- [1] Structural Engineers Association of Southern California (SEAOSC). "Standard Method of Cyclic (Reversed) Load Test for Shear Resistance of Framed Walls for Buildings", 1996a.
- [2] National Design Specification (NDS) for Wood Construction, American Forest and Paper Association, Washington, D.C., 2005.
- [3] Panel Design Specification (PDS), Form No. D510B, APA – The Engineered Wood Association, Tacoma, WA, 2007.
- [4] Performance Rated Rim Board, Form No. W345G. APA-The Engineered Wood Association. Tacoma, WA.
- [5] APA. Cyclic Evaluation of APA Sturd-I-Frame for Engineered Design, APA Report T2002-46, APA-The Engineered Wood Association. Tacoma, WA. 2002.
- [6] APA. Cyclic Evaluation of APA Sturd-I-Frame with 10-ft Height and Lumber Header. APA Report T2003-11, APA-The Engineered Wood Association. Tacoma, WA. 2003a.
- [7] APA. Testing a Portal Frame Design for Use as Bracing in Fully Sheathed Structures, APA Report T2003-48, APA-The Engineered Wood Association. Tacoma, WA. 2003b.
- [8] APA. A Portal Frame Design on Raised Wood Floors for Use as Bracing in Fully Sheathed Structures, APA Report T2004-38, APA-The Engineered Wood Association. Tacoma, WA. 2004.
- [9] APA. Narrow Wall Bracing Tests with No End Restraint, APA Report T2006-29, APA-The Engineered Wood Association. Tacoma, WA. 2006.
- [10] Performance Standard for Wood-Based Structural-Use Panels, PS 2-04, U.S. Department of Commerce, National Institute of Standards and Technology, Gaithersburg, MD, 2004.
- [11] Simpson Strong Tie. Strong Wall Shear Walls, Catalog No. C-SW07, p047-p049. 2007.
- [12] i-Level. Trus-Joist TJ-Shear Panel, #8600 Specifiers Guide. 2006.

APPENDIX A - A CALCULATION EXAMPLE FOR THE HEADER FASTENER MOMENT

Fastener group moment capacity calculation

Fastener Strength

Z =	73	lbf/nail per NDS
C _D =	1.6	
Z' =	116.8	lbf/nail

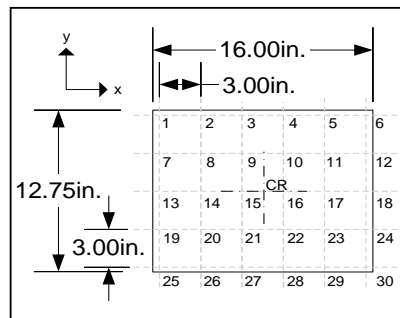

Torsional Analysis

Fastener	x (in.)	y (in.)	dx (in.)	dy (in.)	dx ² (in. ²)	dy ² (in. ²)	dx ² +dy ² (in. ²)	r (in.)
1	0	12	-7.5	6	56.25	36	92.25	9.60
2	3	12	-4.5	6	20.25	36	56.25	7.50
3	6	12	-1.5	6	2.25	36	38.25	6.18
4	9	12	1.5	6	2.25	36	38.25	6.18
5	12	12	4.5	6	20.25	36	56.25	7.50
6	15	12	7.5	6	56.25	36	92.25	9.60
7	0	9	-7.5	3	56.25	9	65.25	8.08
8	3	9	-4.5	3	20.25	9	29.25	5.41
9	6	9	-1.5	3	2.25	9	11.25	3.35
10	9	9	1.5	3	2.25	9	11.25	3.35
11	12	9	4.5	3	20.25	9	29.25	5.41
12	15	9	7.5	3	56.25	9	65.25	8.08
13	0	6	-7.5	0	56.25	0	56.25	7.50
14	3	6	-4.5	0	20.25	0	20.25	4.50
15	6	6	-1.5	0	2.25	0	2.25	1.50
16	9	6	1.5	0	2.25	0	2.25	1.50
17	12	6	4.5	0	20.25	0	20.25	4.50
18	15	6	7.5	0	56.25	0	56.25	7.50
19	0	3	-7.5	-3	56.25	9	65.25	8.08
20	3	3	-4.5	-3	20.25	9	29.25	5.41
21	6	3	-1.5	-3	2.25	9	11.25	3.35
22	9	3	1.5	-3	2.25	9	11.25	3.35
23	12	3	4.5	-3	20.25	9	29.25	5.41
24	15	3	7.5	-3	56.25	9	65.25	8.08
25	0	0	-7.5	-6	56.25	36	92.25	9.60
26	3	0	-4.5	-6	20.25	36	56.25	7.50
27	6	0	-1.5	-6	2.25	36	38.25	6.18
28	9	0	1.5	-6	2.25	36	38.25	6.18
29	12	0	4.5	-6	20.25	36	56.25	7.50
30	15	0	7.5	-6	56.25	36	92.25	9.60
CR	7.5	6				J =	1327.5	

CR = center of rotation

dx = x distance from fastener to center of rotation

dy = y distance from fastener to center of rotation

Results

Longest moment arm (r _{max}) =	9.60	in.	
Critical fastener moment =	16143	lbf-in.	(M = Z' x J / r _{max})
Average moment arm (r _{ave}) =	6.25	in.	
Average fastener moment =	24806	lbf-in.	(M = Z' x J / r _{ave})
Load on critical fastener =	179	lbf	(Z = M x r _{max} / J)

APPENDIX B - A CALCULATION EXAMPLE FOR THE HEADER FASTENER MOMENT**Wood portal frame design value capacity by analysis. Example calculation for wall #1. Sheathed with 3/8" OSB.**

Width = 16	in.
Height = 120	in.
Tie _{down.strap} = 4200	lbf, tie down strap allowable design value
M _{WSP.to.sill} = 3976	lbf-in., determined from fastener group moment capacity calculation
M _{header.fastener} = 24126	lbf-in., determined from fastener group moment capacity calculation
Fb _{WSP} = 600	psi, allowable bedding strength of OSB per APA publication W345
t = 0.375	in. effective thickness of wood structural panel
Strap _{header} = 1000	lbf, header strap allowable design value
F _{tv} = 155	lbf/in., panel shear through the thickness from APA publication D510
Z = 71	lbf, from 2005 NDS Table 11Q for 8d common nails and 3/8" OSB
n = 10	number of nails per foot (based on 2 rows spaced at 3" o.c.)
V _{base.connection} = 1200	lbf, value from 2005 NDS Table 11E for 5/8" anchor bolt bearing on 3 bottom plates.

Step 1. Lateral load capacity, V, based on moment couples**Moment capacity at bottom of portal frame wall segment, M_{bottom}:**

$$M_{\text{bottom}} = \text{Tie}_{\text{down.strap}} \cdot (\text{Width} - 3) + M_{\text{WSP.to.sill}} \quad \text{Note: the 3" is subtracted to sum moment about tie down strap centerline.}$$

$$M_{\text{bottom}} = 58576 \quad \text{lbf-in.}$$

Moment capacity at top of portal frame wall segment, M_{top}

$$M_{\text{WSP}} = Fb_{\text{WSP}} \cdot \frac{t \cdot \text{Width}^2}{6} \cdot 1.6 \quad M_{\text{WSP}} = 15360 \quad \text{lbf-in.} \quad \text{Note: the 1.5" is subtracted to sum moment about strap centerline.}$$

$$M_{\text{header.strap}} = \min[\text{Strap}_{\text{header}} \cdot (\text{Width} - 1.5), M_{\text{WSP}}] \quad M_{\text{header.strap}} = 14500 \quad \text{lbf-in.}$$

$$M_{\text{top}} = \min[M_{\text{WSP}}, M_{\text{header.fastener}}] + M_{\text{header.strap}} \quad M_{\text{top}} = 29860 \quad \text{lbf-in.}$$

Portal frame lateral load capacity based on moment couples, V_{moment.couples}:

$$V_{\text{moment.couples}} = \frac{M_{\text{bottom}} + M_{\text{top}}}{\text{Height}} \quad V_{\text{moment.couples}} = 737 \quad \text{lbf}$$

Step 2. Lateral load capacity, V, based on shear strength**Panel shear capacity, V_{panel} :**

$$V_{panel} = F_{vt} \cdot 1.6 \cdot \text{Width} \quad V_{panel} = 3968 \text{ lbf}$$

The 1.6 is the load duration factor from NDS Table 2.3.2

Nail shear capacity, V_{nails} :

$$V_{nails} = Z \cdot 1.6 \cdot n \cdot \frac{\text{Width}}{12} \quad V_{nails} = 1515 \text{ lbf}$$

The 1.6 is the load duration factor from NDS Table 2.3.2

Portal frame lateral load capacity based on shear strength, $V_{shear \text{ strength}}$:

$$V_{shear \text{ strength}} = \min(V_{panel}, V_{nails}, V_{base \text{ connection}}) \cdot 1.6 \quad V_{shear \text{ strength}} = 1515 \text{ lbf}$$

Step 3. Lateral load capacity, V, based on minimum of moment couples and shear strength**Predicted portal frame lateral load capacity**

$$V = \min(V_{moment \text{ couples}}, V_{shear \text{ strength}}) \quad V = 737 \text{ lbf}$$

Note: the average ultimate value based on testing / 3 = 725 lbf. APA Report T2003-11.