



Wind Load Report

1. Site & Building Data

Roof Type:	Gable
Wind Speed (ult):	115 mph
Exposure Category:	C
Enclosure Class:	Enclosed
Building Width (W):	80 ft.
Building Length (L):	150 ft.
Eave Height (h _e):	18 ft.
Foundation Height (h _f):	0 ft.
Roof Pitch:	2 /12
Eave Overhang (OH _e):	0 ft.
Gable Overhang (OH _g):	0 ft.

2. Parameters & Coefficients

Topographic Factor (K _{zt}):	1.0
Directionality Factor (K _d):	.85
Roof Angle (θ):	9.46 deg.
Mean Roof Height (h):	21.33 ft.
Ridge Height (h _r):	24.67 ft.
Pos. Internal Pressure (+GC _{pi}):	+0.18
Neg. Internal Pressure (-GC _{pi}):	-0.18
Velocity Pressure Exp. Coeff. (K _h):	0.91 @ z=h
Velocity Pressure (q _h):	26.31 psf
End Zone Width (a):	3.00 ft.
Zone 2/2E Dist.:	40.00 ft.

3. Design Assumptions and Notes

Code Standard:	ASCE 7-10
Geometry:	Regular-Shaped Bldg.
Height Class:	Low-Rise Building
Notes:	

4. Design Loads

Top Chord Dead Load:	15 psf
Bottom Chord Dead Load:	0 psf
Truss/Rafter Spacing:	300 in. o/c

4. Design Wind Pressures: MWFRS Envelope Procedure

Load Case A: Transverse Direction			
Surface	GC _{pf}	Design Pressure (psf)	
		(w/ +GC _{pi})	(w/ -GC _{pi})
1	0.44	6.81	16.28
2	-0.69	-22.89	-13.42
3	-0.40	-15.33	-5.86
4	-0.33	-13.46	-3.99
1E	0.67	12.80	22.27
2E	-1.07	-32.89	-23.42
3E	-0.58	-19.93	-10.46
4E	-0.49	-17.69	-8.22

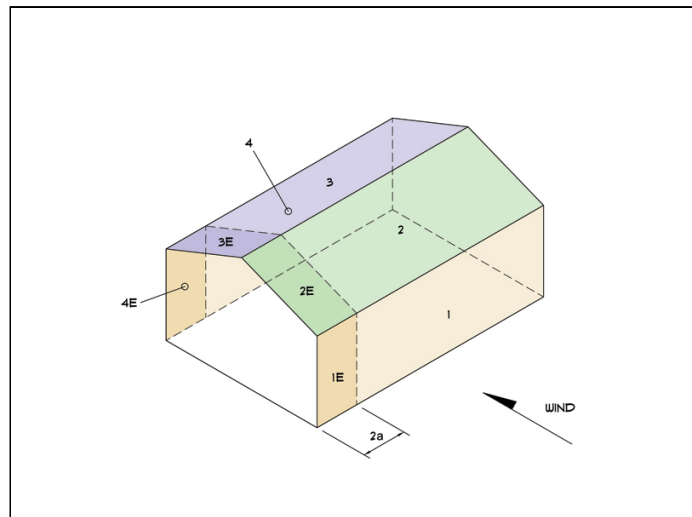

- a) (+) and (-) signs signify wind pressures acting toward & away from surfaces.
- b) External Pressure Coefficients linearly interpolated from Fig. 28.4-1 ASCE 7-10.
- c) Design building for all wind directions, 4 load patterns per load case.
- d) Total horizontal shear shall not be less than that by neglecting roof wind forces.
- e) Min. wind load for enclosed or partially enclosed bldg.: 16 psf wall, 8 psf roof.
- f) Design pressures are for strength design, multiply by 0.6 for ASD.

Subject Wind Loads	Customer	Location	Job No. 2024D382
Engr. Engineer Name	ENGINEERING COMPANY INC.		Rev. -
Date 11/7/2024	Street Address City, CA 99999 ph. (800) 000-0000 www.website.com		Page 1



This report may not be copied, reproduced or distributed without the written consent of Engineering Company Inc.

Load Case B: Longitudinal Direction

Surface	GCpf	Design Pressure (psf)	
		(w/ +GCpi)	(w/ -GCpi)
1	-0.45	-16.57	-7.10
2	-0.69	-22.89	-13.42
3	-0.37	-14.47	-5.00
4	-0.45	-16.57	-7.10
5	0.40	5.79	15.26
6	-0.29	-12.37	-2.89
1E	-0.48	-17.36	-7.89
2E	-1.07	-32.89	-23.42
3E	-0.53	-18.68	-9.21
4E	-0.48	-17.36	-7.89
5E	0.61	11.31	20.78
6E	-0.43	-16.05	-6.58

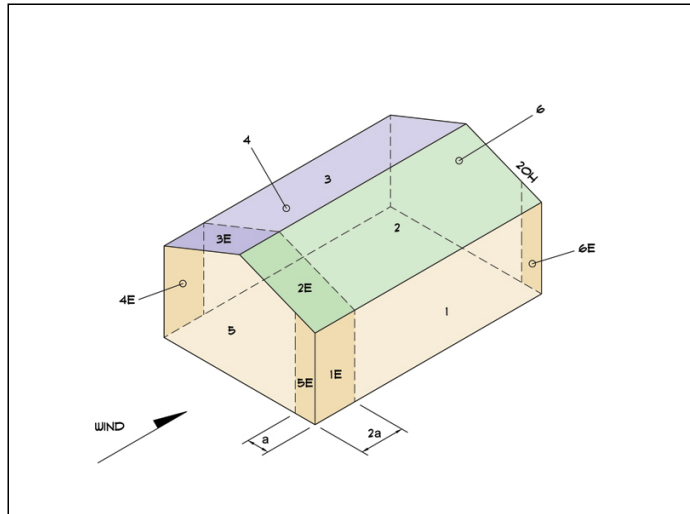

- a) (+) and (-) signs signify wind pressures acting toward & away from surfaces.
- b) External Pressure Coefficients linearly interpolated from Fig. 28.4-1 ASCE 7-10.
- c) Design building for all wind directions, 4 load patterns per load case.
- d) Total horizontal shear shall not be less than that by neglecting roof wind forces.
- e) Min. wind load for enclosed or partially enclosed bldg.: 16 psf wall, 8 psf roof.
- f) Design pressures are for strength design, multiply by 0.6 for ASD.

Torsional Load Cases

Surface	Load Case	GCpf	Design Pressure (psf)	
			(w/ +GCpi)	(w/ -GCpi)
1T	A	-	1.70	4.07
2T	A	-	-5.72	-3.35
3T	A	-	-3.83	-1.46
4T	A	-	-3.37	-1.00
5T	B	-	1.45	3.81
6T	B	-	-3.09	-0.72

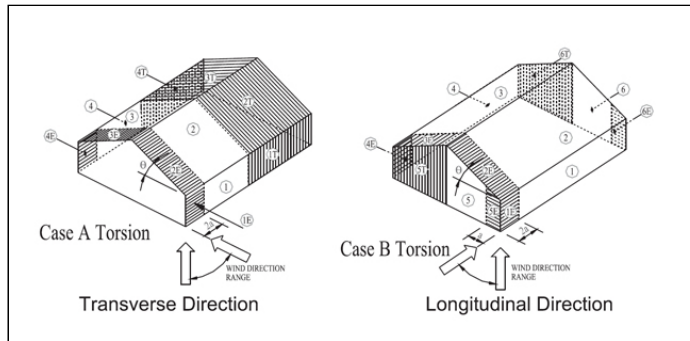

- a) (+) and (-) signs signify wind pressures acting toward & away from surfaces.
- b) Pressures designated with a "T" are 25% of full design wind pressures.
- c) Torsional loading shall apply to all 8 load patterns using the figures shown.
- d) Design pressures are for strength design, multiply by 0.6 for ASD.
- e) Torsional Design Exceptions: One story bldg. with $h \leq 30$ ft,
Two stories or less framed with light frame construction,
Two stories or less with flexible diaphragms.

Subject Wind Loads	Customer	Location	Job No. 2024D382
Engr. Engineer Name	ENGINEERING COMPANY INC. Street Address City, CA 99999 ph. (800) 000-0000 www.website.com		Rev. -
Date 11/7/2024			 This report may not be copied, reproduced or distributed without the written consent of Engineering Company Inc. Copyright © 2024

5. Wind Load Calculations

1.) Lateral Loads - Transverse Direction:

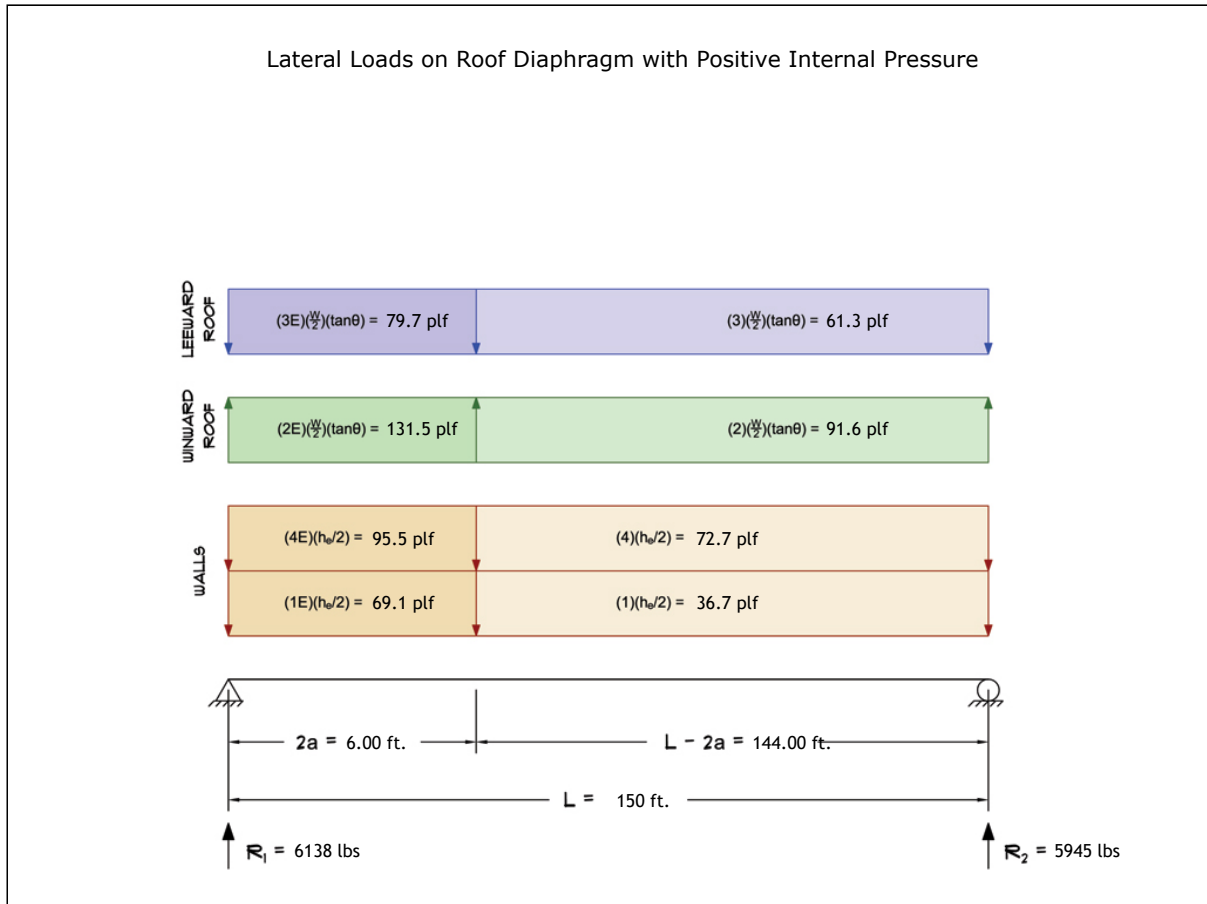

- a) (-) signs signify wind lateral forces acting opposite to the direction of the arrows shown.
 b) Strength design values multiplied by 0.6 to obtain ASD values.

Wind Base Shear (ASD)						
Load Case A: Transverse Direction						
Load Case	Walls (lbs)	Roof (lbs)	Roof Overhangs (lbs)	Total Lateral Load (lbs)	R ₁ (lbs)	R ₂ (lbs)
Positive Internal Pressure	16747	-4664	0	12083	6138	5945
Negative Internal Pressure	16747	-4664	0	12083	6138	5945
Roof Pressure = 0	16747	0	0	16747	8533	8215
Min. Pressures (8 psf, 16 psf)	12960	4800	0	17760	8880	8880

- a) Bottom half of wall neglected in tributary area calculations.
 b) Strength design values multiplied by 0.6 to obtain ASD values.

Subject Wind Loads	Customer	Location	Job No. 2024D382
Engr. Engineer Name	ENGINEERING COMPANY INC.		Rev. -
Date 11/7/2024	Street Address City, CA 99999 ph. (800) 000-0000 www.website.com		Page 3



This report may not be copied, reproduced or distributed without the written consent of Engineering Company Inc.

2.) Lateral Loads - Longitudinal Direction:

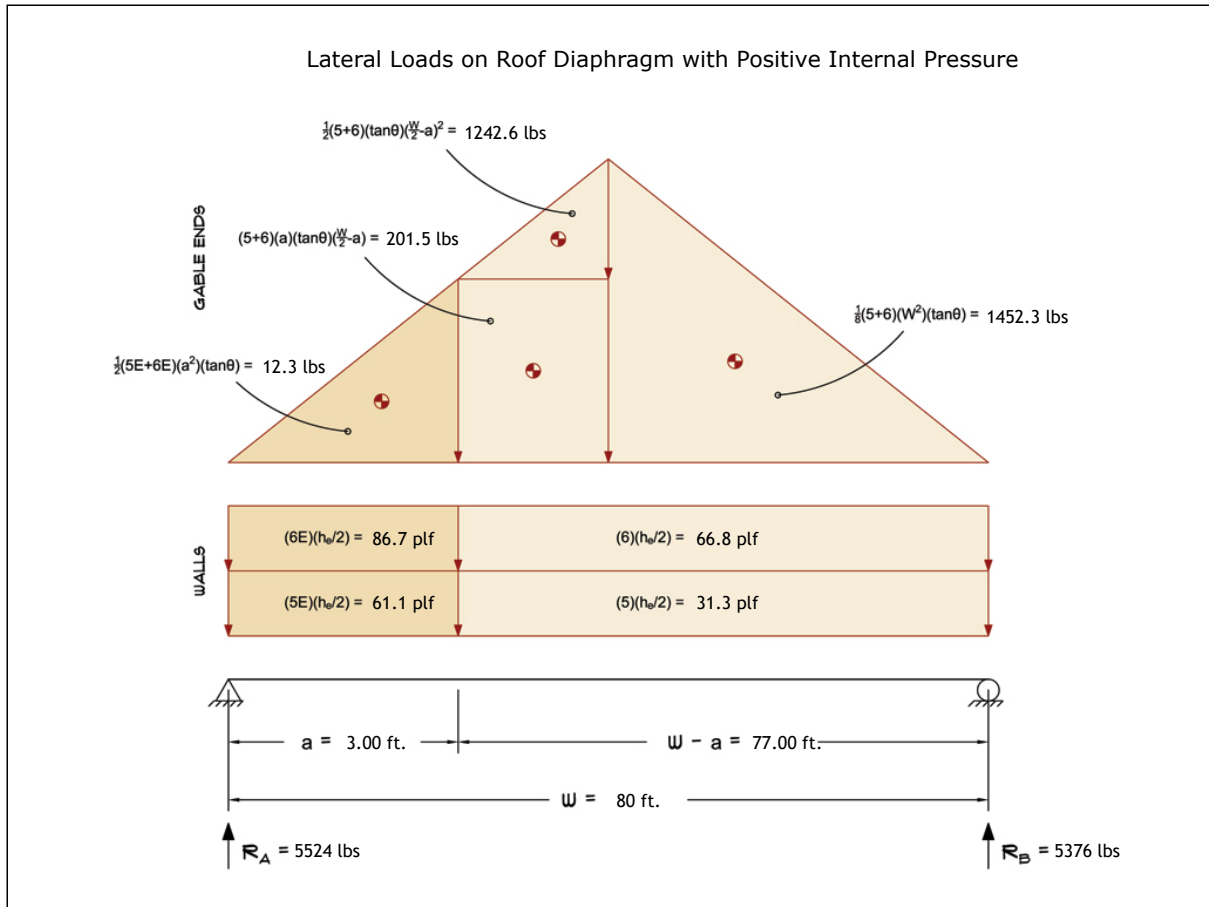

- a) (-) signs signify wind lateral forces acting opposite to the direction of the arrows shown.
- b) Strength design values multiplied by 0.6 to obtain ASD values.
- c) Where the length of building (L) exceeds 4X the mean roof height (h), wind drag forces should additionally be considered.

Wind Base Shear (ASD)						
Load Case B: Longitudinal Direction						
Load Case	Walls (lbs)	Gable Ends (lbs)	Roof (lbs)	Total Lateral Load (lbs)	R _A (lbs)	R _B (lbs)
Positive Internal Pressure	7991	2909	0	10900	5524	5376
Negative Internal Pressure	7991	2909	0	10900	5524	5376
Roof Pressure = 0	7991	2909	0	10900	5524	5376
Min. Pressures (8 psf, 16 psf)	6912	2560	0	9472	4736	4736

- a) Bottom half of wall neglected in tributary area calculations.
- b) Strength design values multiplied by 0.6 to obtain ASD values.

Subject Wind Loads	Customer	Location	Job No. 2024D382
Engr. Engineer Name	ENGINEERING COMPANY INC.		Rev. -
Date 11/7/2024	Street Address City, CA 99999 ph. (800) 000-0000 www.website.com		Page 4

This report may not be copied, reproduced or distributed without the written consent of Engineering Company Inc.

Copyright © 2024

3.) Roof Truss Reactions:

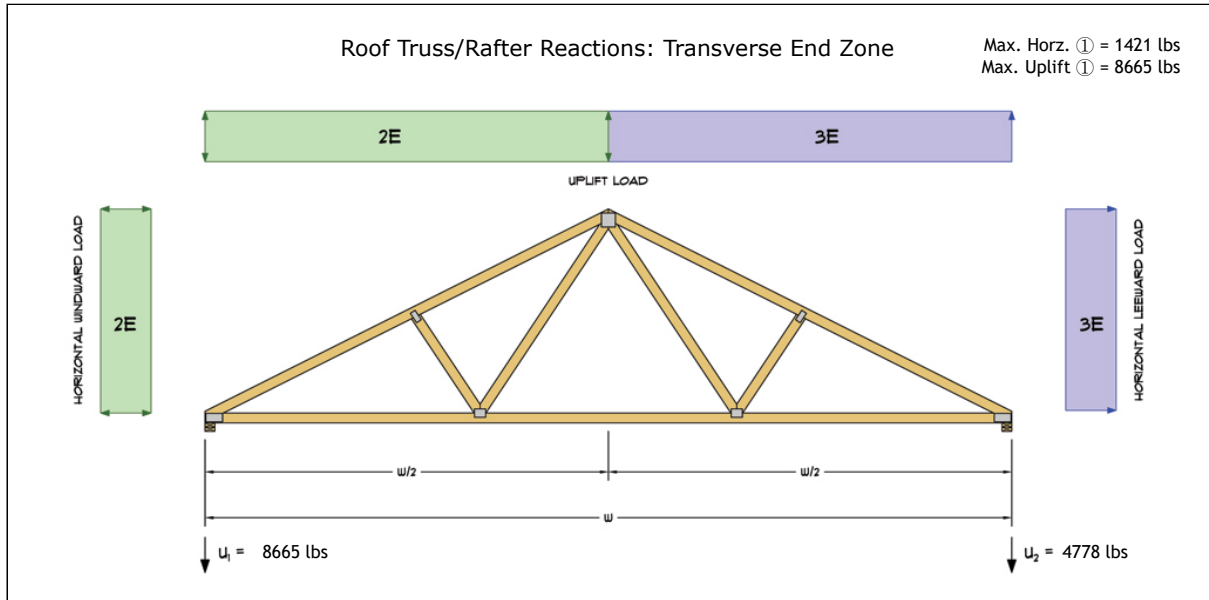

- a) Strength design values multiplied by 0.6 to obtain ASD values.
- b) Windward loads may be positive or negative depending on pitch of roof.

Roof Truss/Rafter Reactions (ASD)					
w/ Positive Internal Pressure					
Load Case	Horizontal Load (lbs)	Gross Uplift (lbs)	Net Uplift (lbs)	U ₁ (lbs)	U ₂ (lbs)
Transverse Int. Zone	756	22932	4684	3476	1208
Transverse End Zone	1295	31691	13443	8665	4778
Longitudinal Int. Zone	842	22415	4167	3346	821
Longitudinal End Zone	1421	30940	12691	8477	4215

- a) Gross Uplift calculations do not include any counteracting roof dead loads.
- b) Net Uplift calculations include counteracting roof dead loads multiplied by 0.6 per load case (7) ASCE 7-10.
- c) Strength design values multiplied by 0.6 to obtain ASD values for wind loads.
- d) Loads based on truss spacing calculated at 300" o/c.
- e) Negative values for horizontal load indicate load acting in windward direction (transverse load cases).
- f) Negative values for uplift indicate net downward force (zero uplift).

*Disclaimer: The calculations produced herein are for initial design and estimating purposes only. The calculations and drawings presented do not constitute a fully engineered design. All of the potential load cases required to fully design an actual structure may not be provided by this calculator. For the design of an actual structure, a registered and licensed professional should be consulted as per IRC 2012 Sec. R802.10.2 and designed according to the minimum requirements of ASCE 7-10. The wind load calculations provided by this online tool are for educational and illustrative purposes only. Medeek Design assumes no liability or loss for any designs presented and does not guarantee fitness for use.

Subject Wind Loads	Customer	Location	Job No. 2024D382
Engr. Engineer Name	ENGINEERING COMPANY INC.		Rev. -
Date 11/7/2024	Street Address City, CA 99999 ph. (800) 000-0000 www.website.com		Page 5



This report may not be copied, reproduced or distributed without the written consent of Engineering Company Inc.