

5 HDQ8 INSTALLATION DETAILS

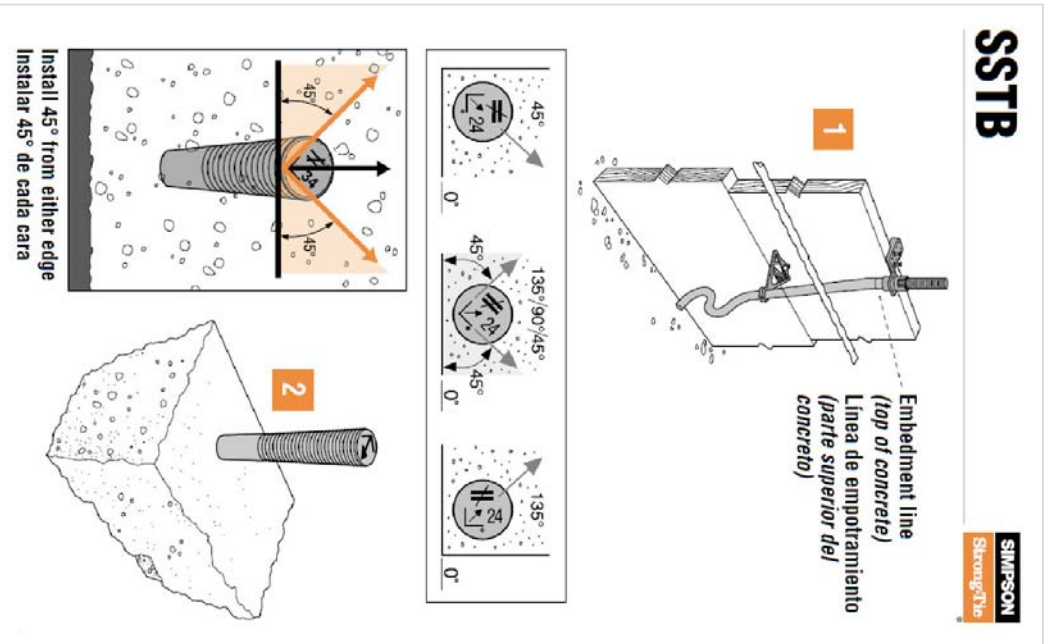

6 SSTB INSTALLATION DETAILS

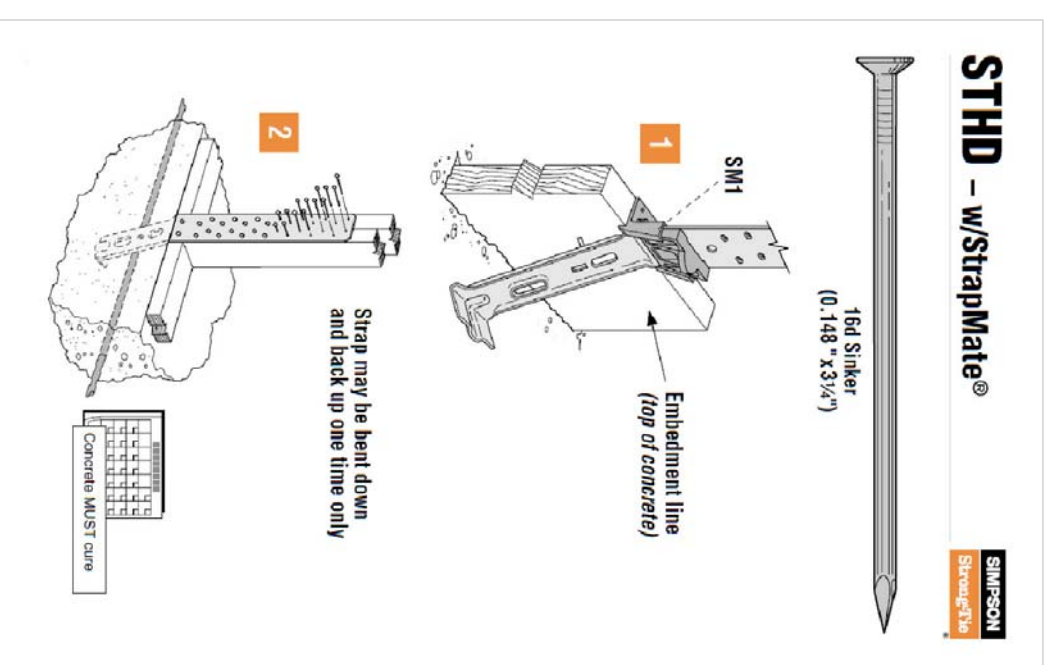

7 STHD4 INSTALLATION DETAILS

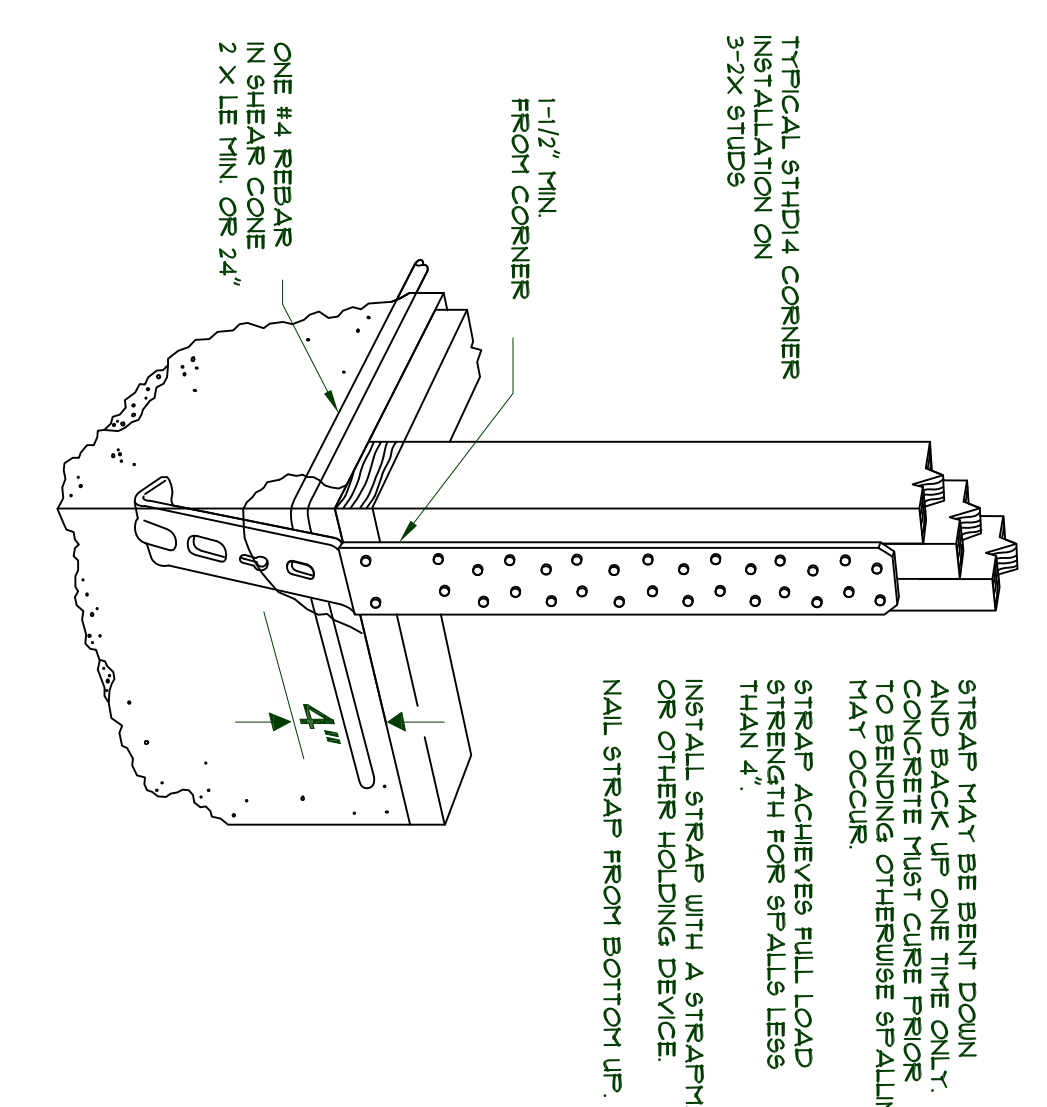

8 STHD4 CORNER INSTALLATION DETAILS

- FRAMING DETAIL NOTES:**
1. VERIFY ROUGH OPENING DIMENSION FOR ALL FASTENERS INTO PRESTRESSED CONCRETE. MUST CURE PRIOR TO BENDING OTHERWISE SPALLING MAY OCCUR.
 2. ALL GIRDER TRUSSES SHALL HAVE A MIN. OF (2) STUDS BELOW FOR BEARING.
 3. ROUGH CARPENTERS SHALL INSTALL ADDITIONAL BACKING FOR ANY INTERIOR STUDS, WALLS, KITCHENS AND CONTRACTORS SHALL VERIFY MISSING OR INCORRECT DIMENSIONS WITH WEDEEK DESIGN.

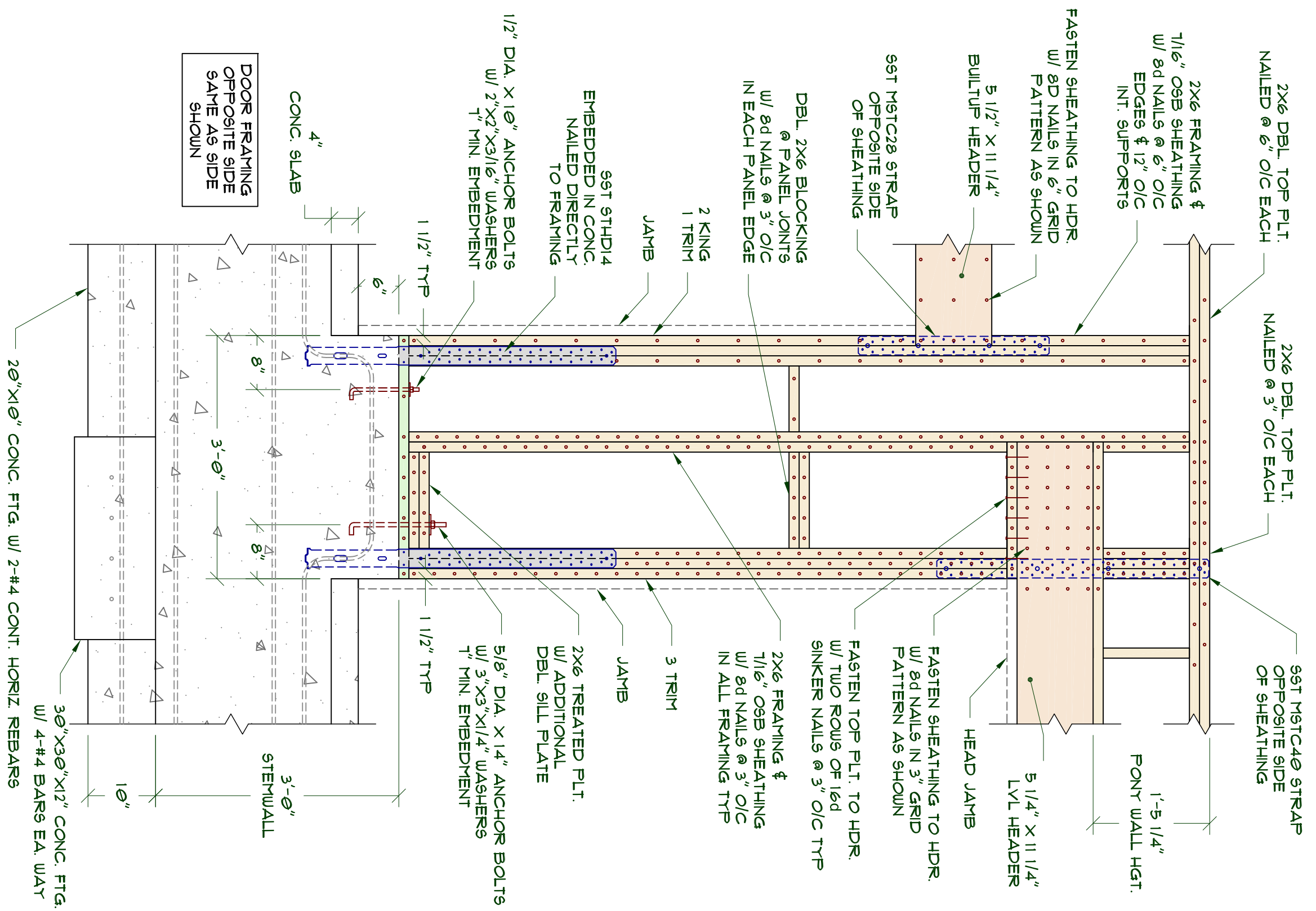

1 DOOR/GARAGE DOOR SEPARATOR

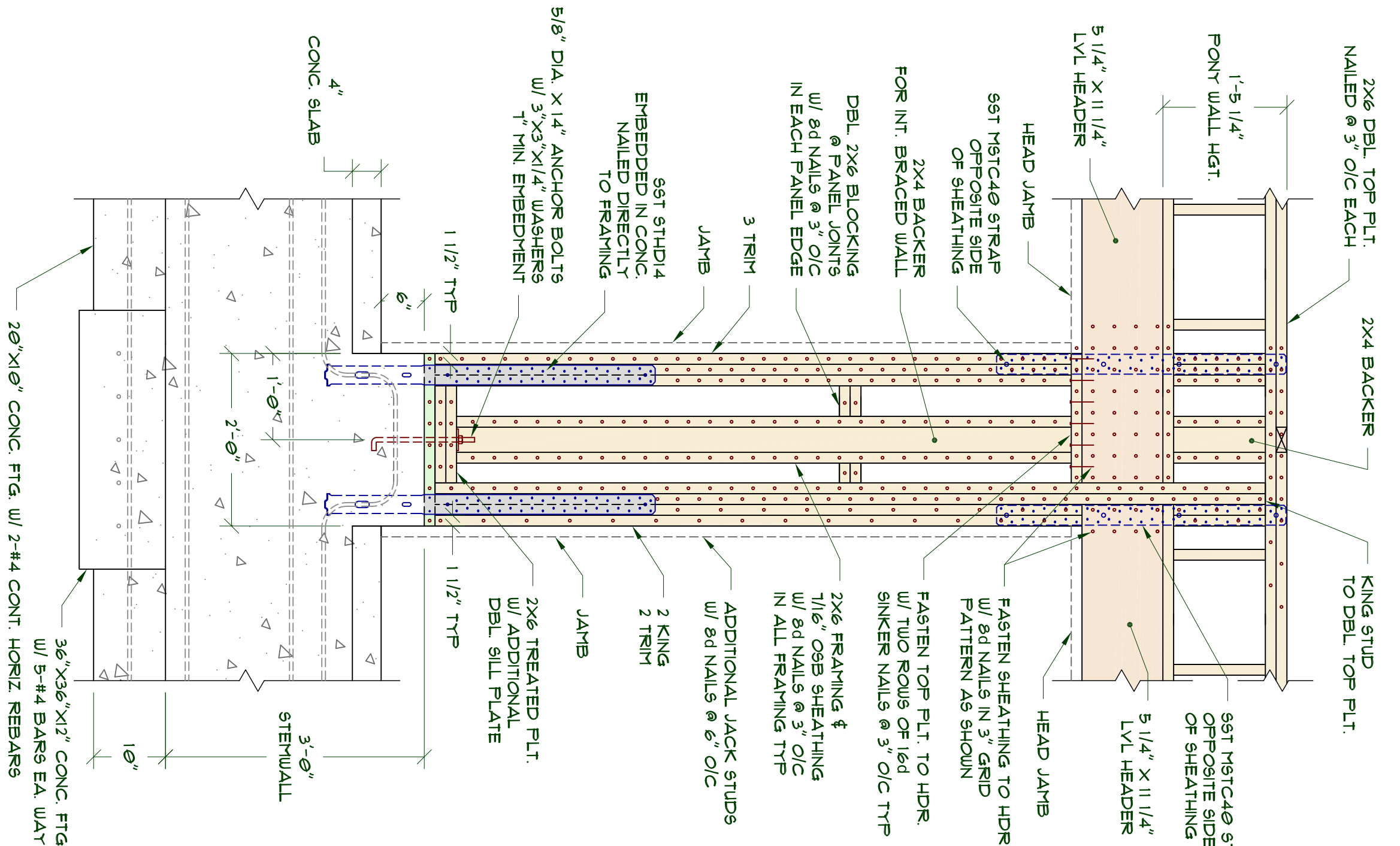

2 GARAGE DOOR SEPARATOR 1

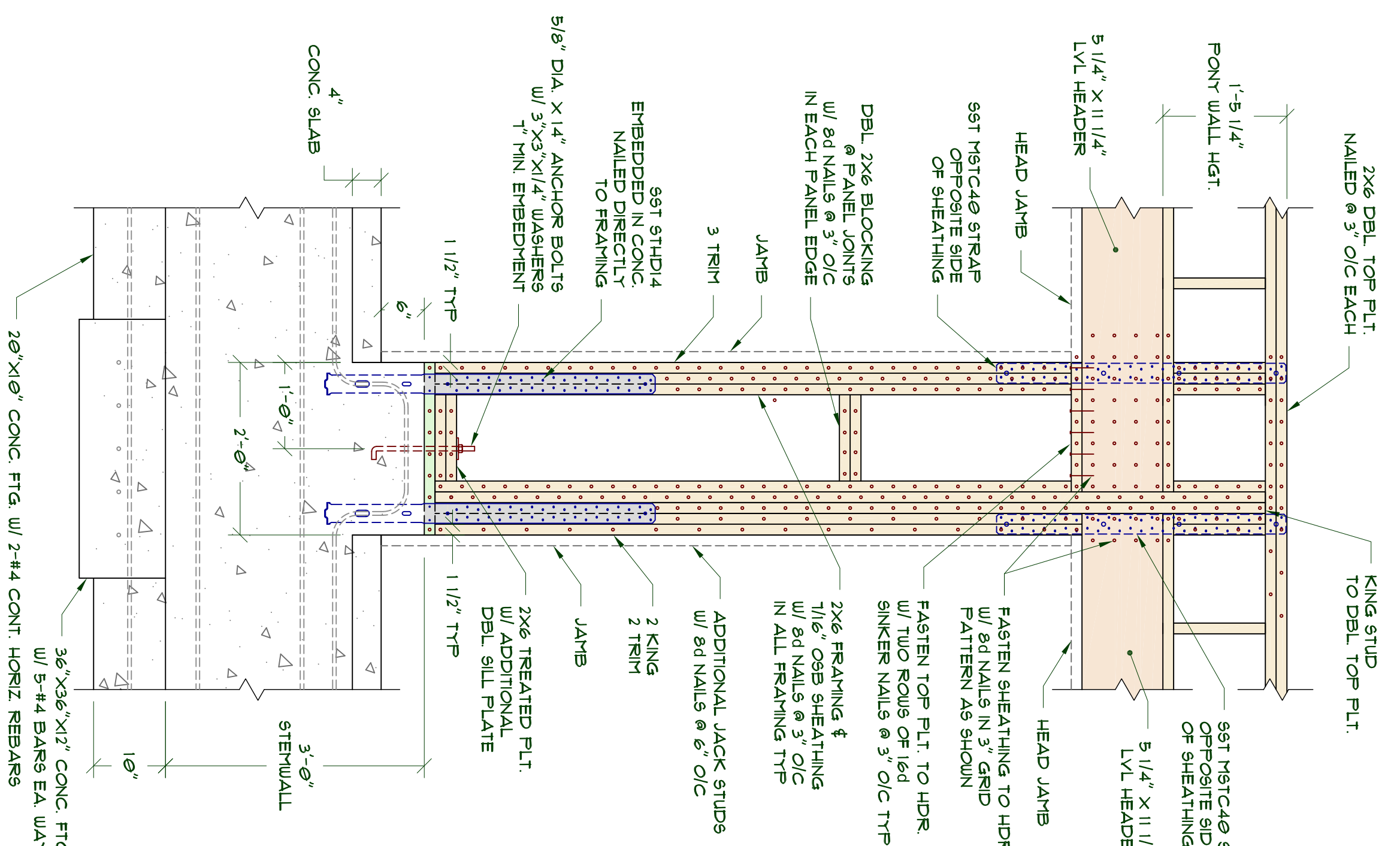

3 GARAGE DOOR SEPARATOR 2

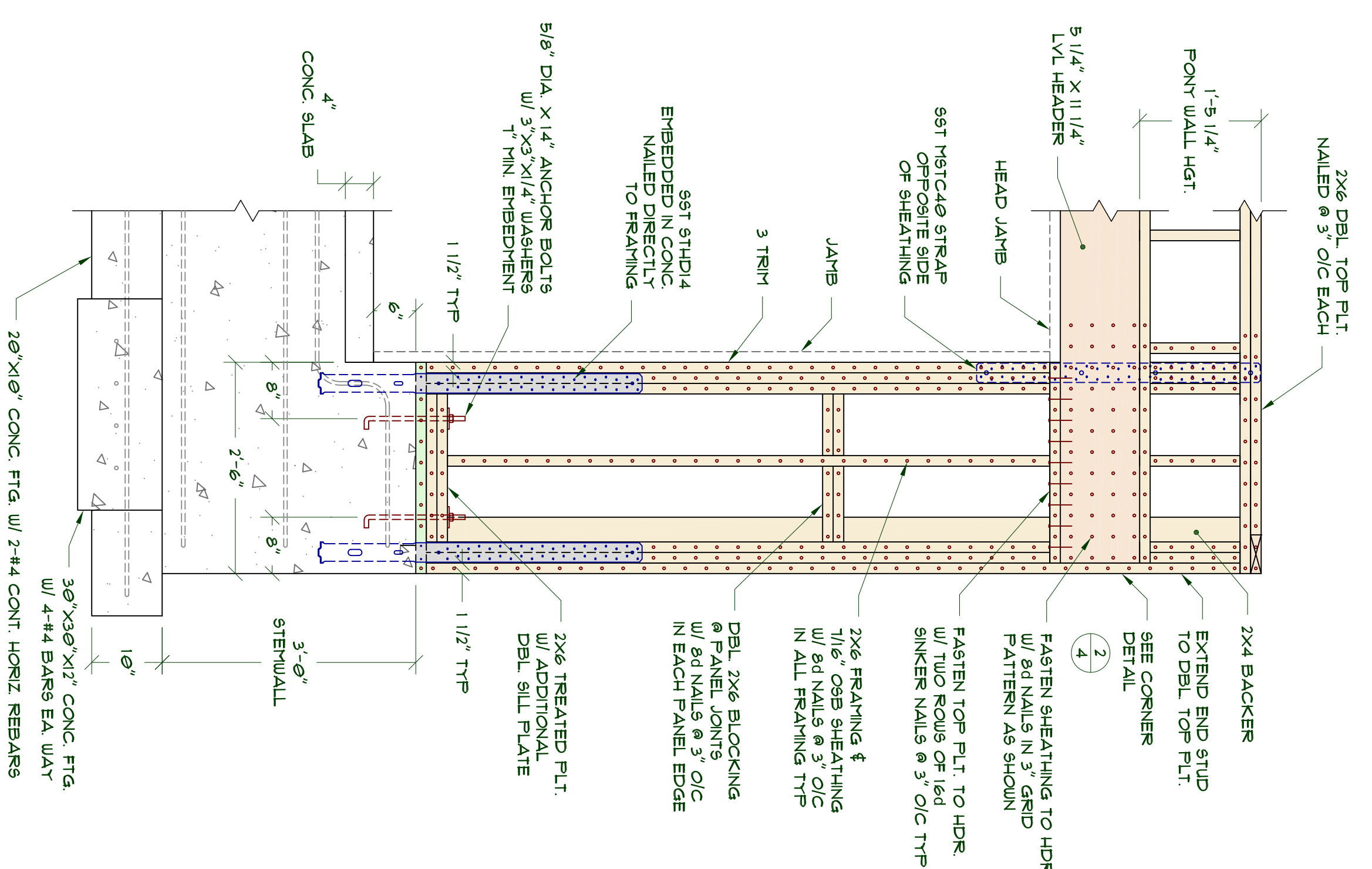

4 GARAGE DOOR END PANEL

ALTERNATE BRACED WALL PANEL AND PORTAL FRAME DETAILS

NOTE: NOT ALL REBAR SHOWN FOR CLARITY

